

# EST-P20

## Sound projector

### Overview

---

Fire alarm EST-P20, EST-P20P loudspeakers have been designed and manufactured for the most demanding customers as well as to meet the requirements of the most complex and sophisticated sound transmitting applications. Thanks to the contribution of advanced technologies they combine excellent acoustic parameters and high aesthetics with resistance to mechanical damages and varying weather conditions as well as low prices. Their additional quality is an exceptionally quick and simple installation.

Quality standards and audio characteristics have been confirmed through tests and trials in an anechoic chamber, resistance and integrity testing equipment, as well as chambers for resistance to weather and air humidity testing. The need to maintain the best acoustic parameters was the idea underlying the design process. EST-P loudspeaker models emitting the sound which features directional characteristic and high efficiency. 5-inch 2-cone wide band loudspeakers used in these series are excellent alternative solution for horn-type units due to wide frequency band. They prove excellent in both musical and verbal applications. EST-P20 and EST-P20P loudspeakers are enclosed in round casings made of extruded aluminum; they feature a high class of protection from humidity. Thanks to directional characteristic of sound propagation our loudspeakers are mostly applied on circulation routes and in wide area sound emission. Due to resistance to weather conditions the loudspeakers prove excellent in industrial halls, warehouses, as well as partly open spaces exposed to outdoor weather conditions. Apart from high mechanical and functional resistance EST-P loudspeakers entirely comply with global requirements for systems, including also the British Standard No. BS5839 Part 8 and EN 54-24. Technical solutions applied in the design ensure continuous operations of sound-transmitting line connected with the loudspeaker even in the case the latter is damaged or burnt as a result of fire. The said protection is composed of ceramic blocks installed inside the loudspeaker, internal fireproof wiring, and temperature limit fuse. Two sound-transmission cable penetrations in the casing are insulated by means of two cable glands. Inside the fire zone the loudspeaker is isolated from the entire line, which ensures line continuity and uninterrupted broadcasting of emergency messages. The individual power rating is selected by means of connection with applicable transformer branch.

EST-P loudspeakers are designed for continuous operations at rated parameters for at least 100 hours in compliance with the IEC-268-5 Standard.

EST-P20P loudspeakers are designed for pendant mounting. They are equipped with an additional junction box enabling simple and quick speaker installation. They are used wherever the distance from ceiling mounted speaker is too large.



### Details

---

- Designed to achieve directional characteristic of sound emission
- 20 W transformer with multiple branches ensuring accurate selection of output power
- Enclosed in an advance and functional cylindrical casing made of extruded aluminium
- Ideal for either ceiling or wall installation
- Fireproof casing with ceramic block and thermal fuse
- High sound quality in music and speech emission

# EST-P20

## Sound projector

### Especificaciones técnicas

---

#### Eléctrico

Consumo de corriente	20 W
Voltaje de funcionamiento de la línea	100 V
Nivel de salida	79 dB
Frecuencia	130 to 20000

#### Físico

Dimensiones físicas	143 x 210 mm (Ø x H)
Peso neto	2.4 kg
Color	Blanco (RAL 9003)
Tipo de Montaje	Soporte de pared
Posición de montaje	Techo, Pared
Material de la carcasa	Aluminio extruido

#### Medioambiental

Temperatura de funcionamiento	-25 to 70°C
Entorno	Interior, Exterior
Clasificación IP	IP66

#### Regulador

Normativas	EN54-24 BS5839-8 thermal protection
------------	--

---

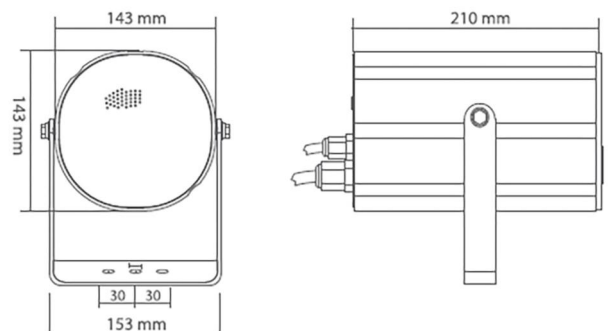

Como empresa innovadora, Carrier Fire & Security se reserva el derecho de modificar las especificaciones de los productos sin previo aviso. Para conocer las últimas especificaciones de los productos, visite la Web de [es.firesecurityproducts.com](http://es.firesecurityproducts.com) o póngase en contacto con su comercial.

Last updated on 14 February 2024 - 9:24